

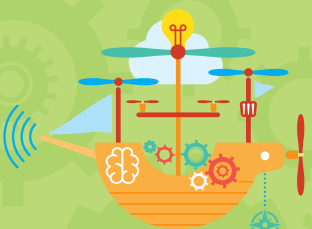

Structural Design

Grades 6-8

CURRICULUM SAMPLE



STEAM
ENRICHMENT

edventures.com

sales@edventures.com

(208) 343-3110



COMPLETE PROGRAM



PRINT MATERIALS



SAMPLE BUILD



Structural Design

GRADES: 6-8

STUDENTS Up to 30	TIME 12, one-hour lessons
SUBJECTS • Technology	SETTINGS • Summer camps • Classrooms • Before & After-school programs

Learners explore advanced building and blueprinting techniques, integrate mechanics into construction and investigate the engineering design process through projects with real-world applications.

♻️ 100% reusable

TECH REQUIREMENTS / PREREQUISITES

- None

PRICING OPTIONS

- Complete Program: \$3,495⁰⁰
- Curriculum Print & Digital: \$425⁰⁰



Scan or Click QR Code for:

[PRODUCT ORIENTATION](#)

[FULL MATERIALS LIST](#)

[STANDARDS & ALIGNMENT](#)

CONTACT US:

Call: (208) 343-3110

Email: sales@edventures.com

Web: edventures.com



Project 2

2

TOWER DESIGN

Tall structures require more sophisticated structural thinking and planning, though the basic approach is the same as those you considered in the post and lintel builds (bracing, orienting members to resist shear and bending). Here, you explore some tower design concepts through the construction of a couple of models.

KEY POINTS

- Bracing is critical in towers. The taller the structure, the more tendency to bend.
- Bracing in towers can also serve as functional members (tall decking, for example).
- Note: there must be a balance of mass distribution. The more bracing you add, the stiffer the structure, and the faster the sway frequency becomes, so bracing can work against damping (adding mass at the top as you did with the previous project).

2

It's time to BUILD!

MODULAR TOWER

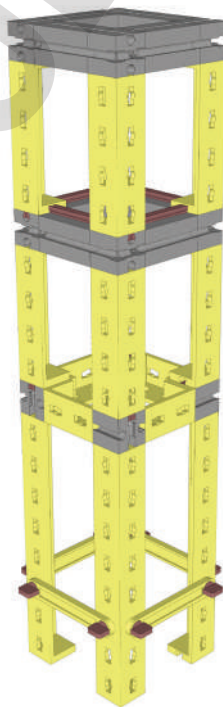

Legend



Set assembly aside.



Build the number shown.



Rotate assembly.



Flip assembly.

Materials you will need:



Building Block 30
(Qty 8)



Building Block 15
(Qty 12)



Rivet 4
(Qty 8)



Spring Cam
(Qty 8)



Spring Cam
(Qty 4)



I-Strut 45
(Qty 4)



Angle Girder 30
(Qty 4)



Angle Girder 60
(Qty 8)



Angle Girder 120
(Qty 4)

1



x4



x4



x4

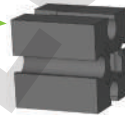

All steps have an "exploded view" which helps with assembly.

The assembly should look like this before going on to the next step.



x4

2



x2

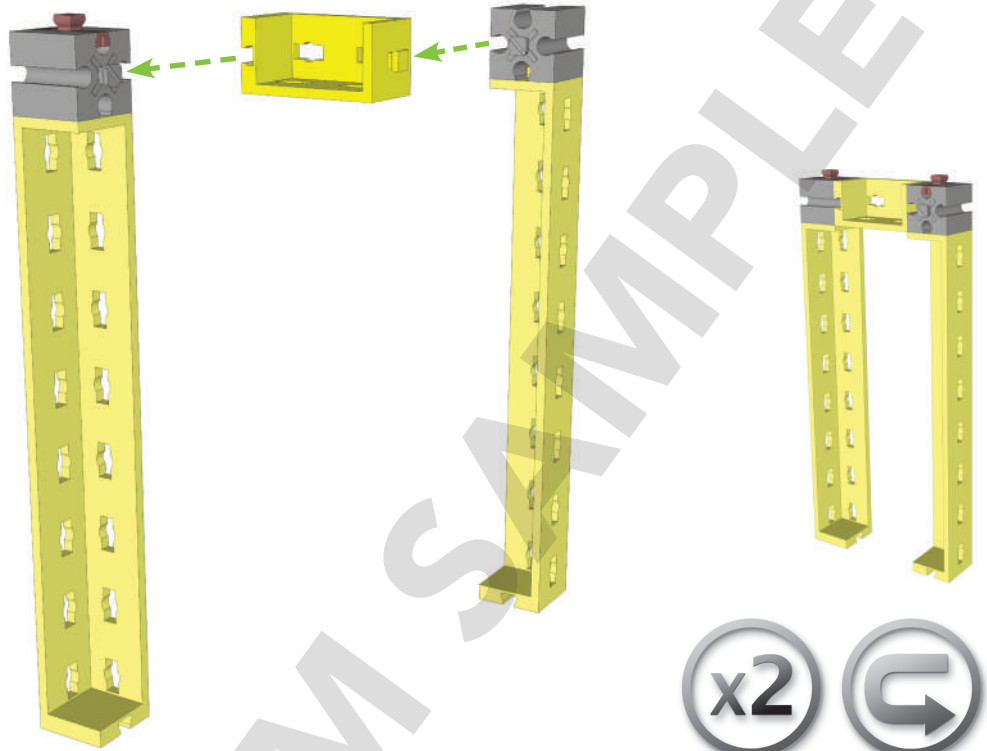

3



x1

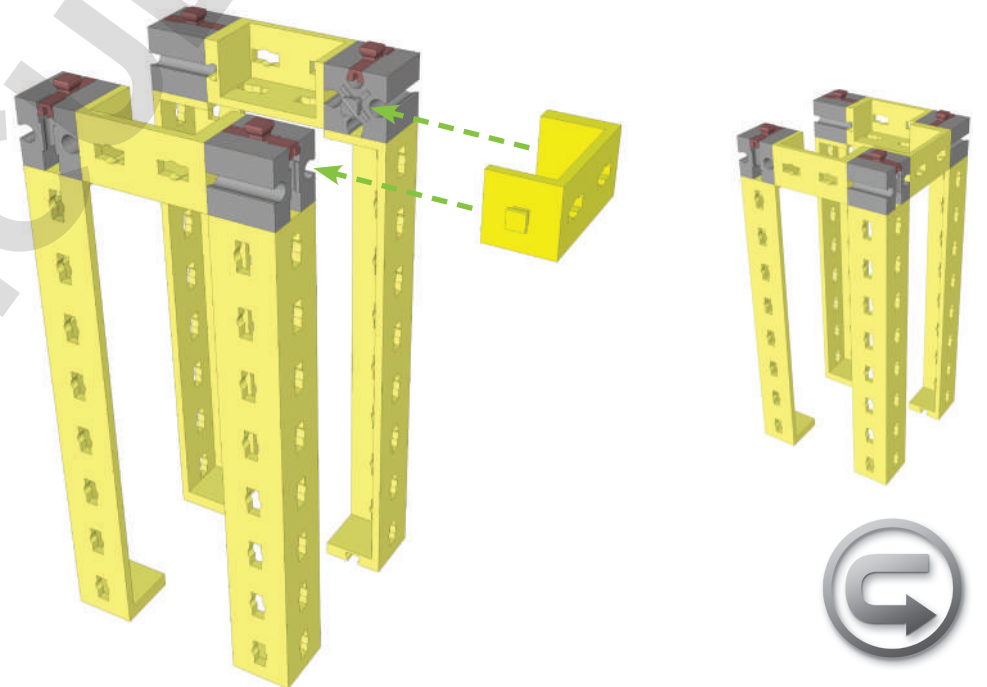

4



x1

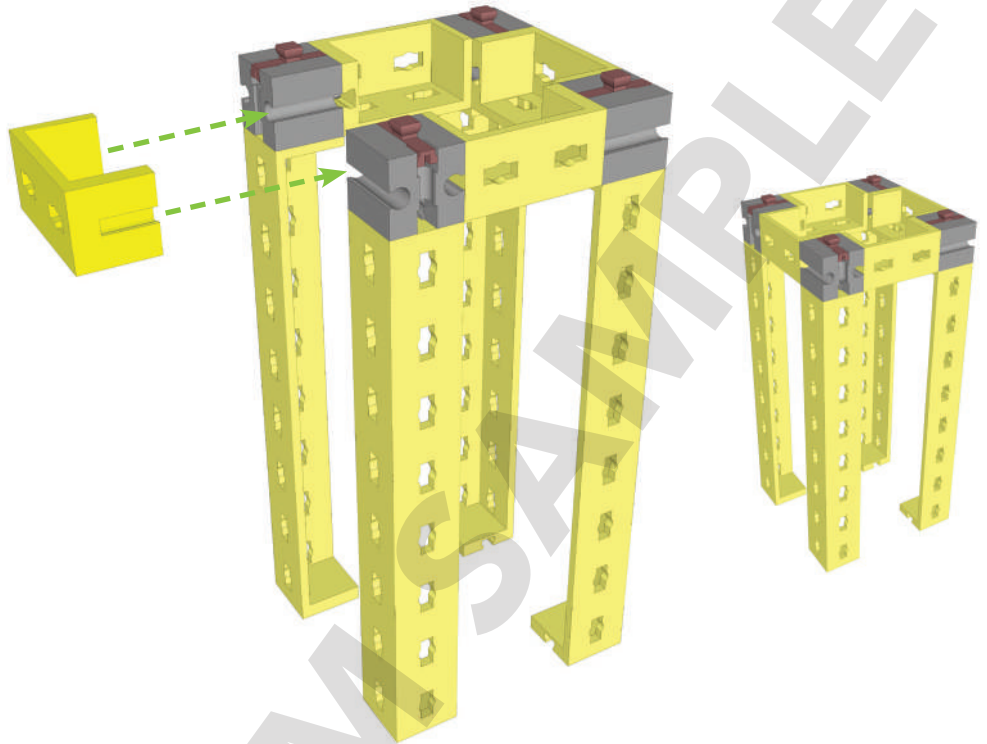

5



x2



x1

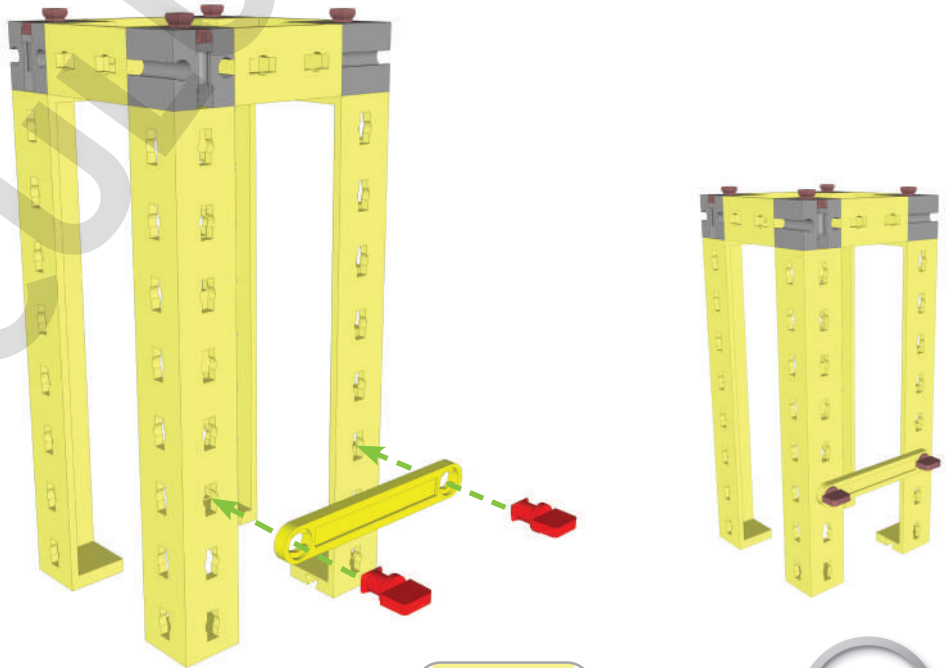

Twist the Rivet 4 to join the strut assembly to the Angle Girder 120s.



6



x2



x1

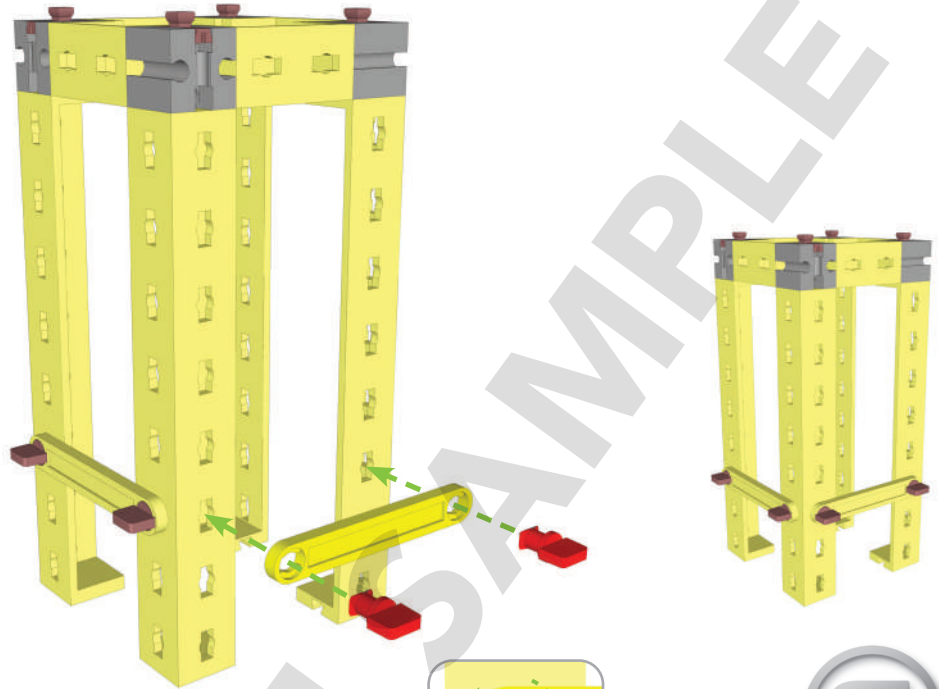

Twist the Rivet 4 to join the strut assembly to the Angle Girder 120s.

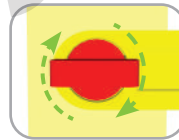

7



x2



x1

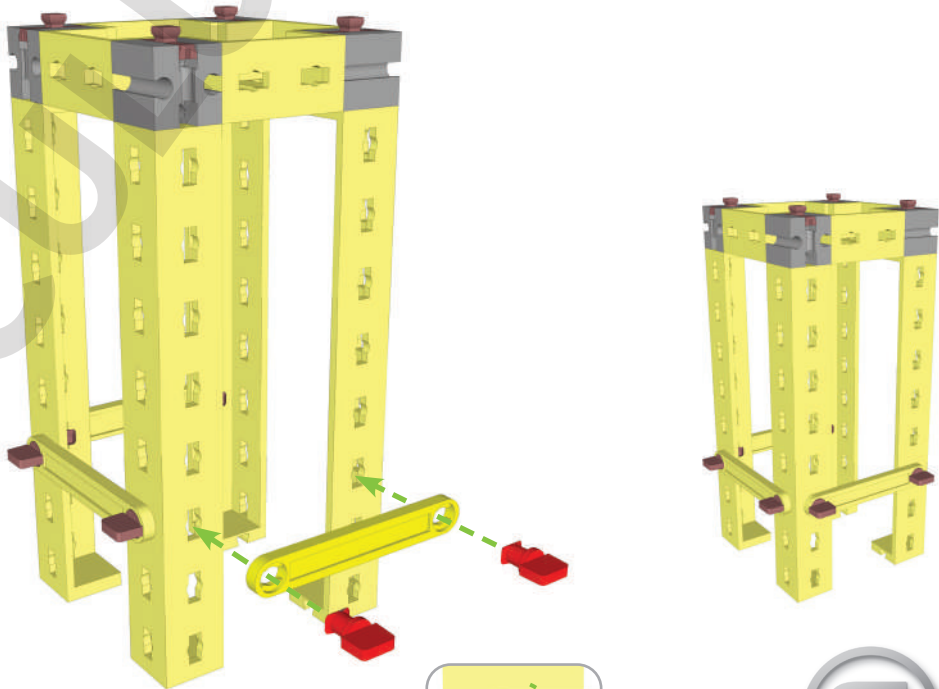

Twist the Rivet 4 to join the strut assembly to the Angle Girder 120s.

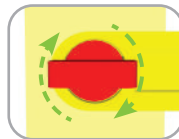

8



x2



x1

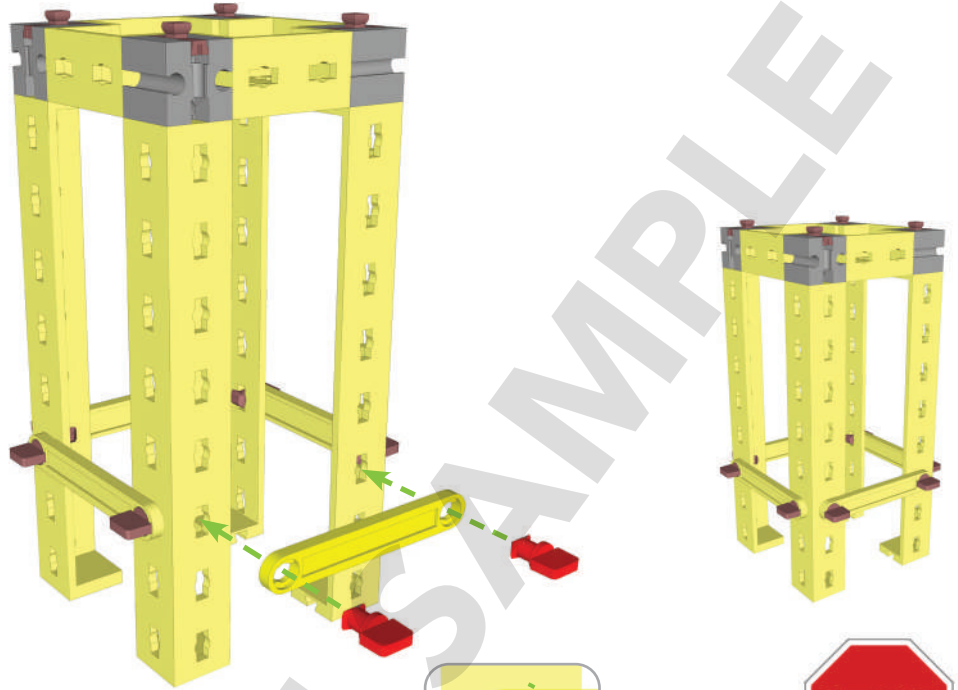

Twist the Rivet 4 to join the strut assembly to the Angle Girder 120s.

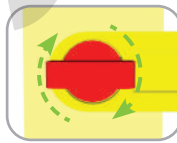

9

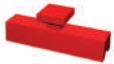

x4



x4



x4

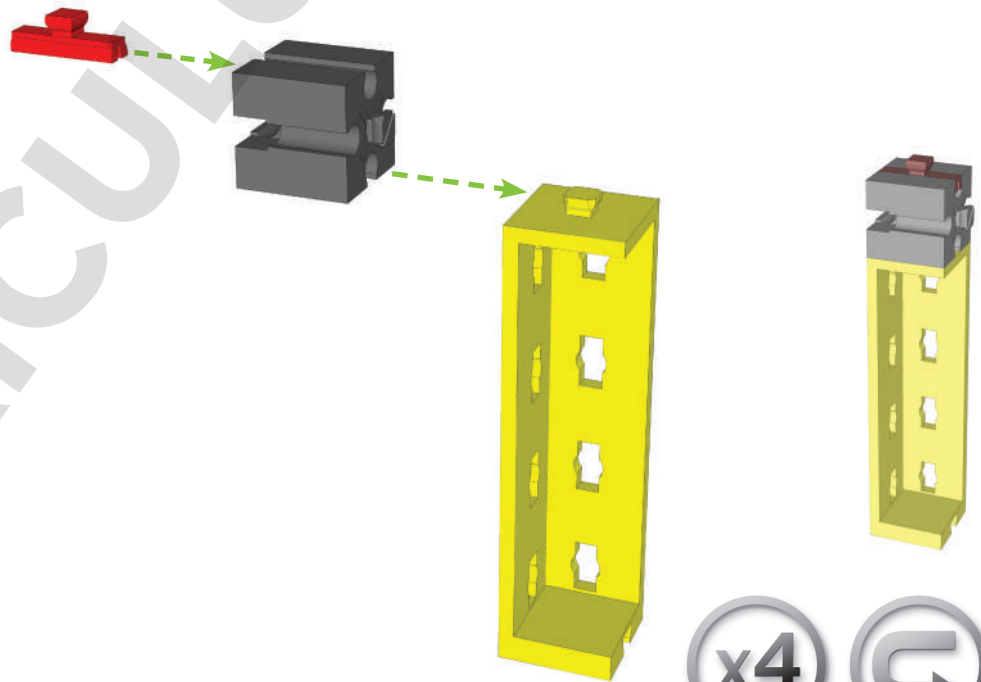

10

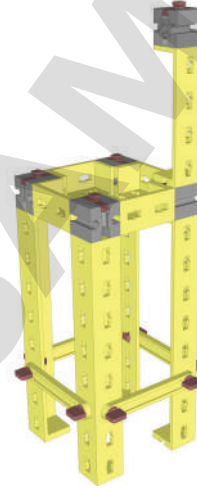
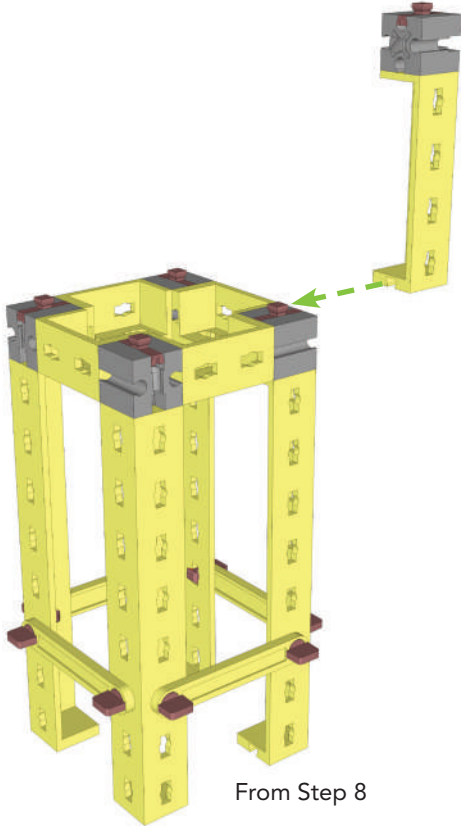

11

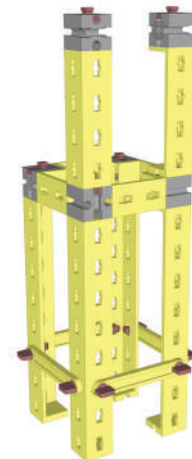
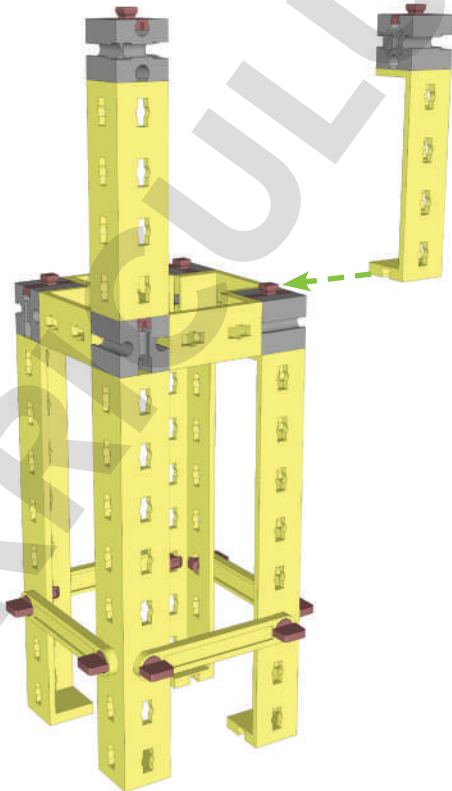

12

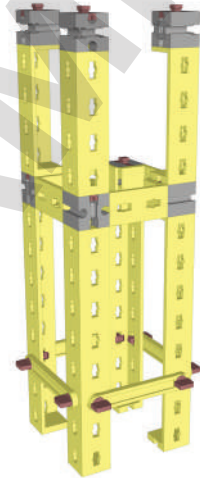
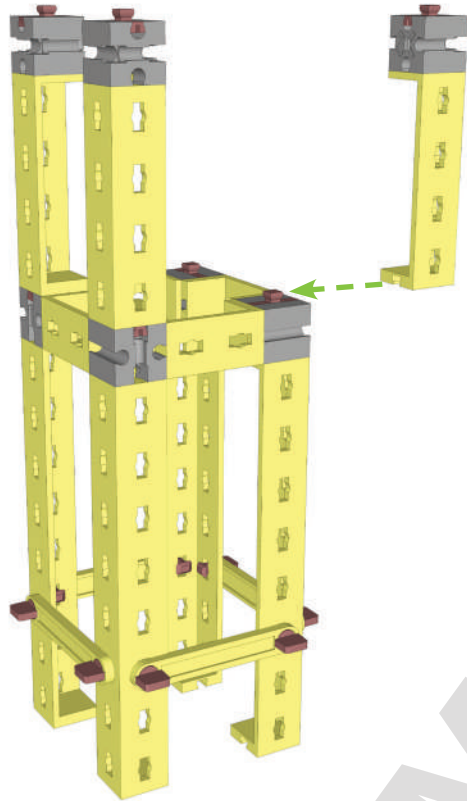

13

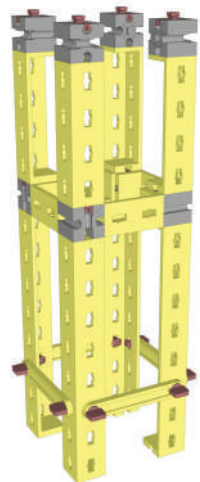
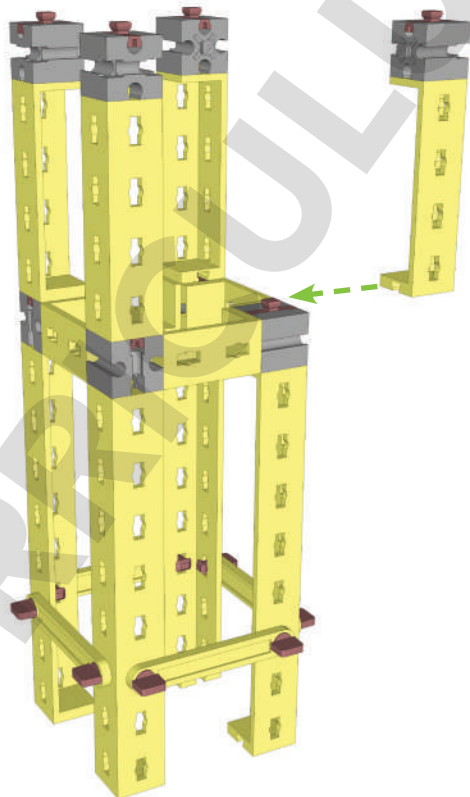

14



x4



x4

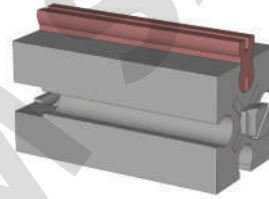
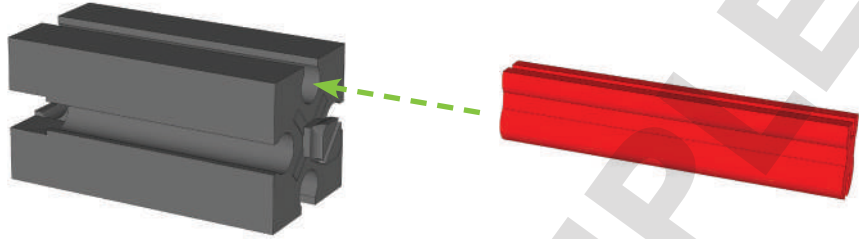

15

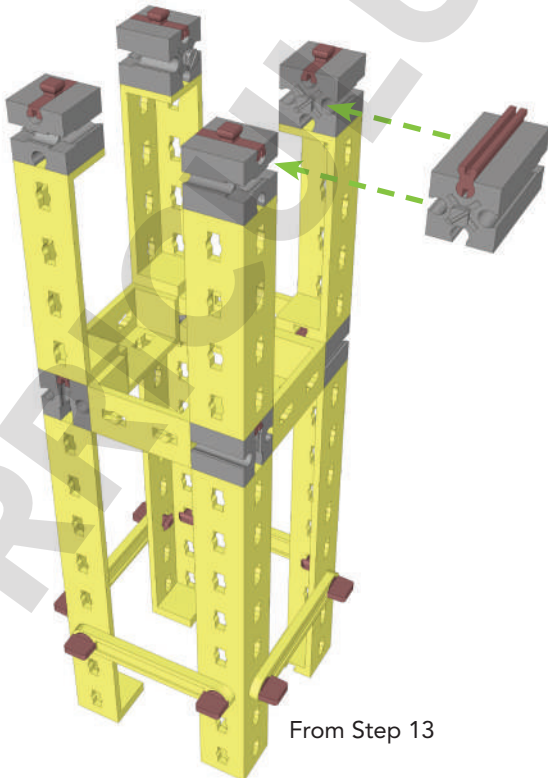

From Step 13

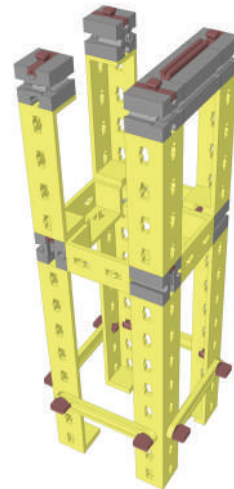

16

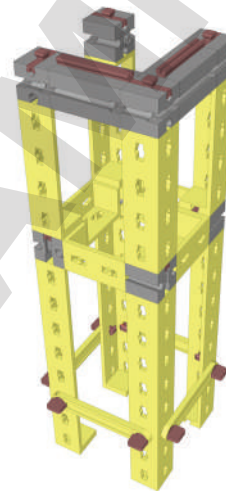
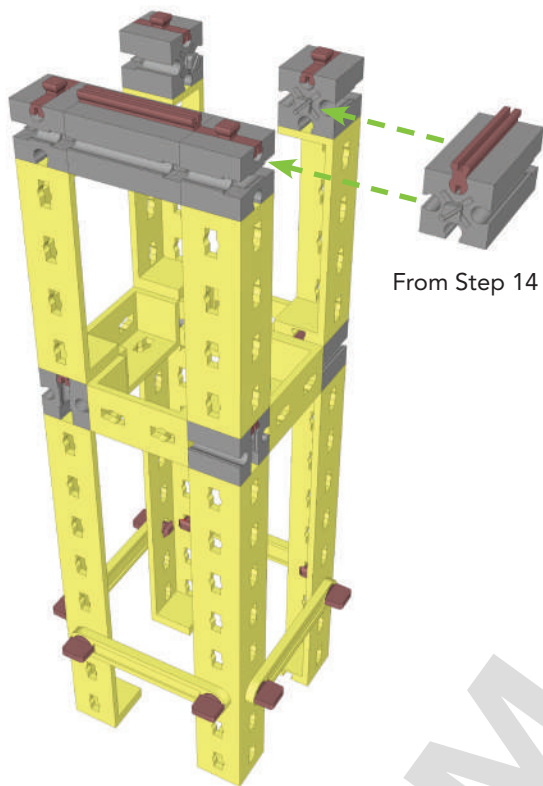

17

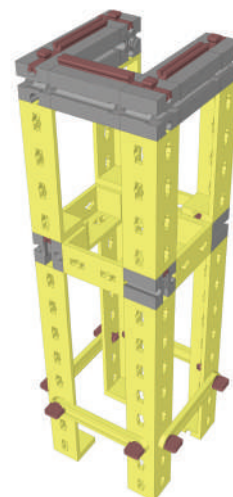
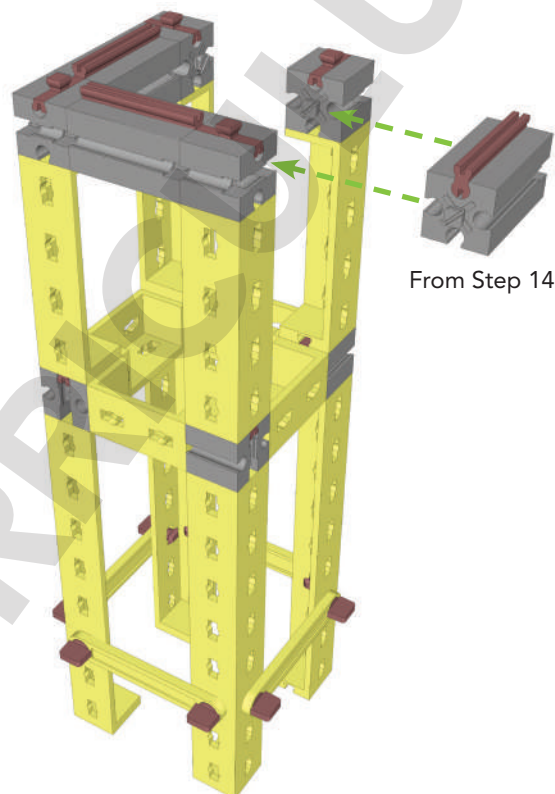

18

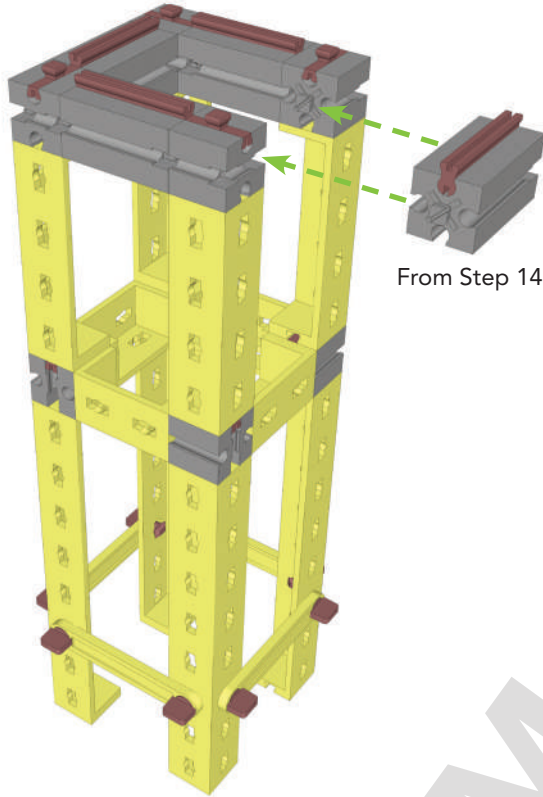

From Step 14

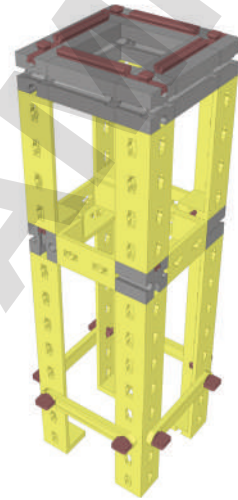

19



x4



x4

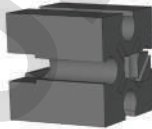

20

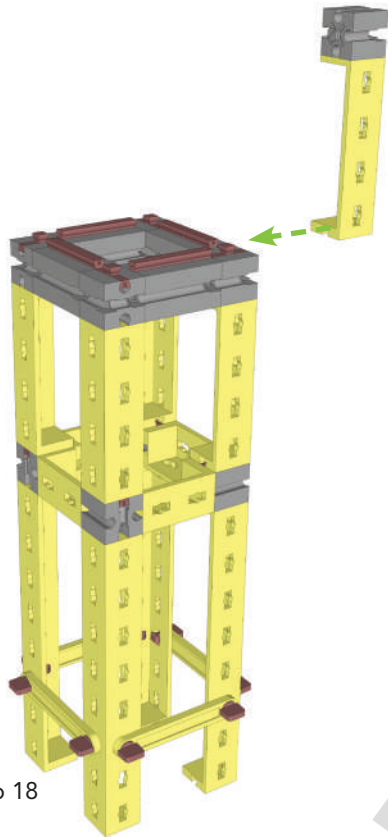

From Step 18

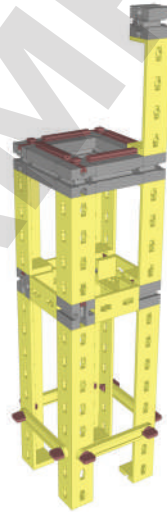

21

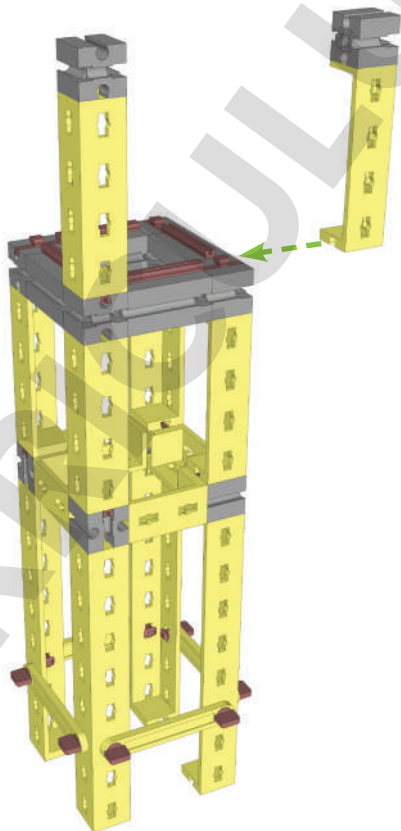

From Step 19

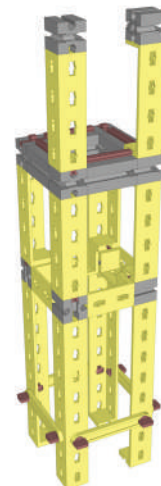

22

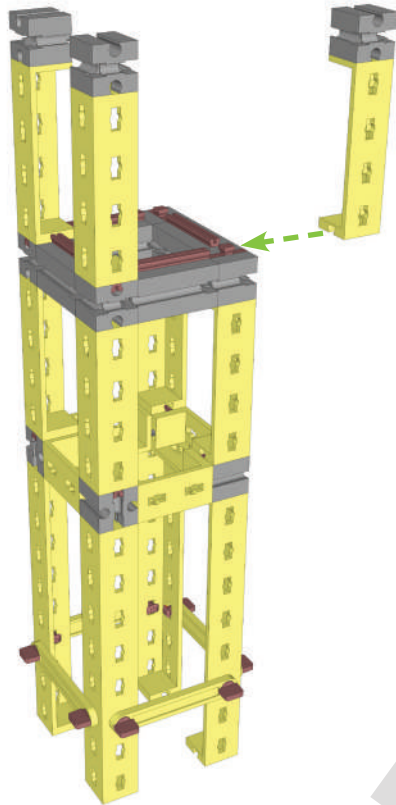

From Step 19

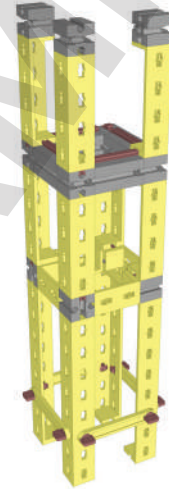

23

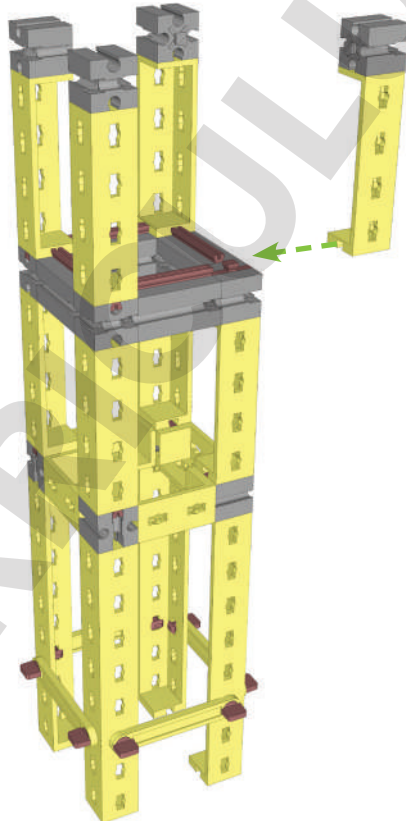

From Step 19

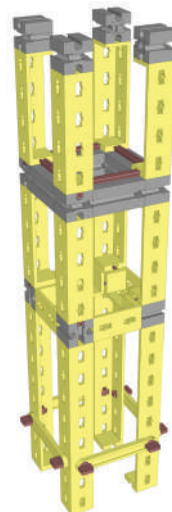

24



x1

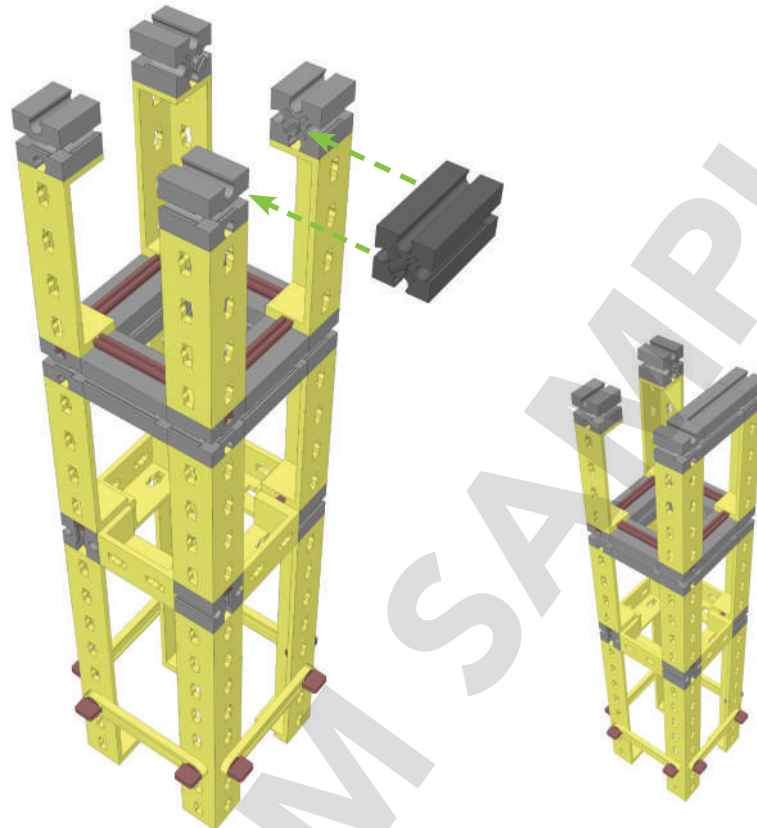

25



x1

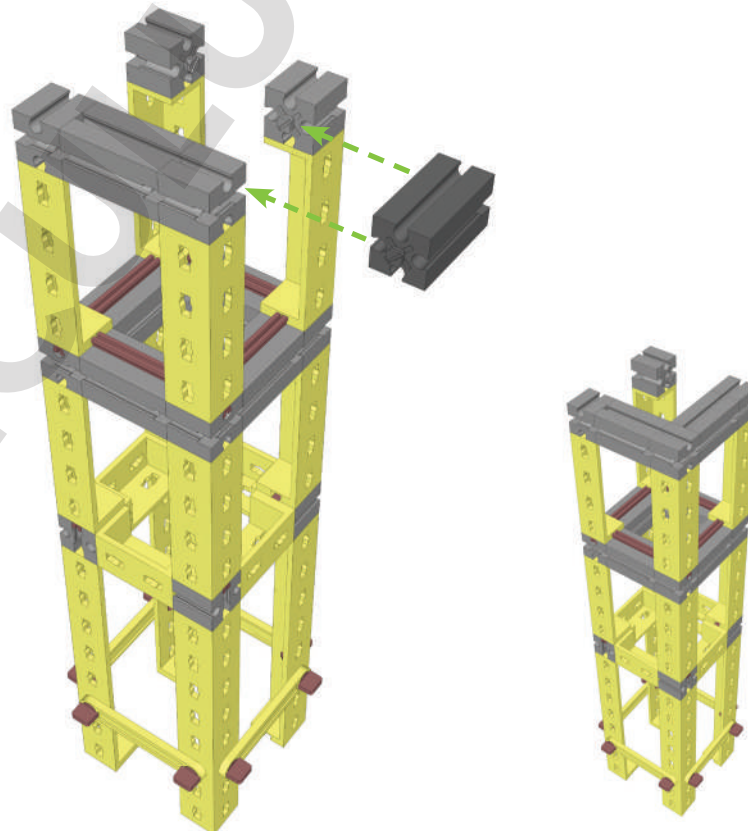

26



x1

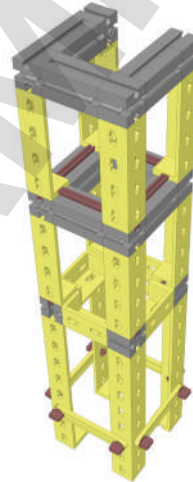
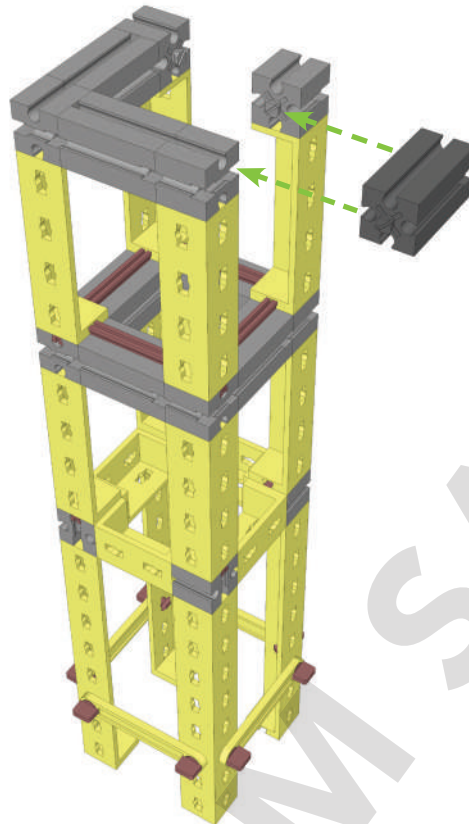

27



x1

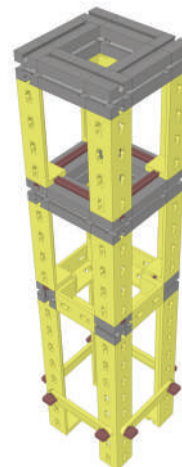
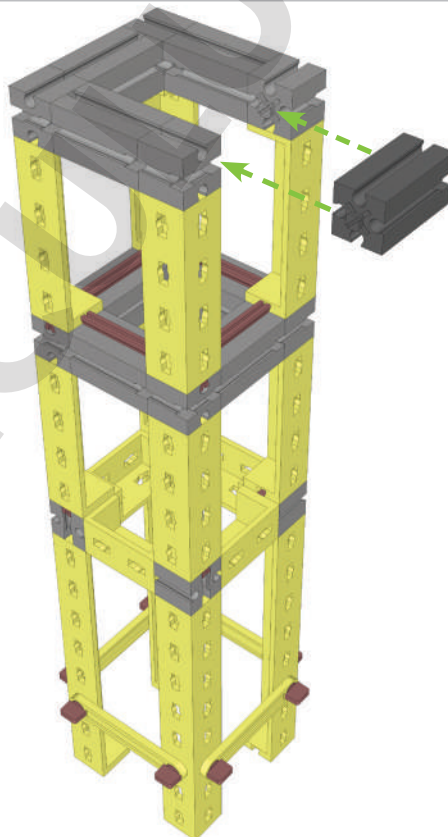

Finished Model

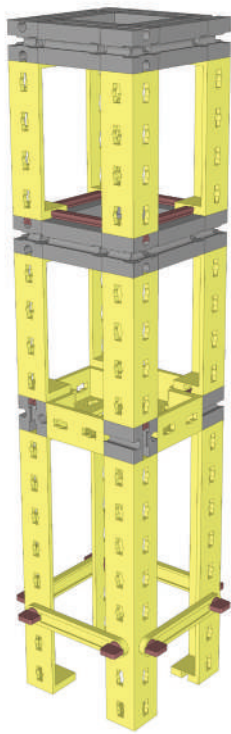

You may have noticed that this structure applies the concepts you used in Level 1, (from your post and lintel models). In this case, like with most multi-story buildings, floor decks provide horizontal bracing. Note that no x-struts were used.

If you wish to make the tower even more sturdy, where might you put x-struts? Try a couple of configurations and see if you can determine which provides the most support and efficiency. Would x-struts help with efficiency? You may choose to modify the location of any elements in the tower build.

Think about the shaking frequency of your tower (as you might get from an earthquake). Your tower is probably too stiff to see this, but you might imagine that the more bracing you add, the stiffer it gets, and that a stiff object will wobble at a much higher frequency than a floppy object. This is something to consider when designing in an earthquake zone. Sometimes it's better to reduce the bracing (though usually not -- because there are other things to consider besides earthquakes).

If you choose to use either extension, be sure to focus your positive commentary on groups' willingness to share their ideas for the advancement of the whole class, rather than on specific groups' designs. Remember that it is paramount to continually foster a climate of collaboration. At the close of this extension, point out that everyone is applying one or more of these design strategies in their subsequent builds.

Extension

OPTION 1:

Present your team's braced tower, along with an explanation of why you thought that your bracing configuration was the most effective (think about strength and efficiency). Demonstrate the resistance to flexibility.

OPTION 2:

Each tower, with x-struts added, is displayed in the room. Teams of 2 do a gallery walk and select the bracing configuration that seems most effective, and the one that seems most efficient. Individual teams are asked to explain their choices to the group (why they thought the selected models were most efficiently braced).



Need a Custom Solution?

Call: (208) 343-3110

Email: sales@edventures.com

Web: edventures.com



PCS edventures!TM
 Experts in Hands-On **STEM** Education

