

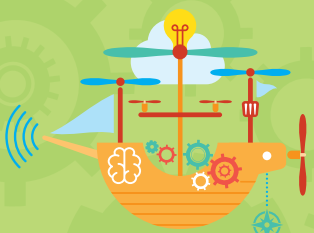

Simple Machines

Grades 4-6

CURRICULUM SAMPLE



STEAM
ENRICHMENT

edventures.com

sales@edventures.com

(208) 343-3110



Simple Machines

GRADES: 4-6



COMPLETE PROGRAM



PRINT MATERIALS

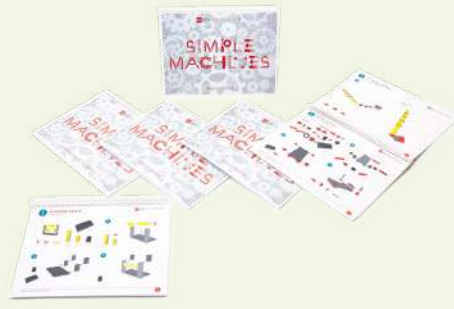

SAMPLE BUILDS



STUDENTS
Up to 30

TIME
12, one-hour lessons

SUBJECTS

- Technology
- Engineering Design

SETTINGS

- Summer camps
- Classrooms
- Before & After-school programs

In this **hands-on** STEM program, learners investigate mechanical engineering through step-by-step builds. Using the **engineering design process**, learners build levers, pulleys and inclined planes.

♻️ 100% reusable

TECH REQUIREMENTS / PREREQUISITES

- None

PRICING OPTIONS

- Complete Program: \$1,545⁰⁰
- Curriculum Print & Digital: \$425⁰⁰

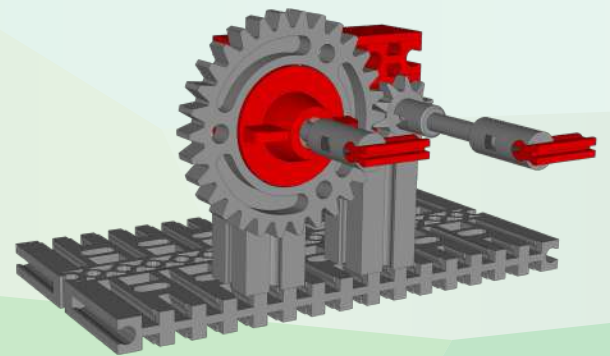

Scan or Click QR Code for:

PRODUCT ORIENTATION

FULL MATERIALS LIST

STANDARDS & ALIGNMENT

CONTACT US:

Call: (208) 343-3110

Email: sales@edventures.com

Web: edventures.com





STEM CONNECTIONS

Engineering: Defining Problems and Developing Solutions



MATERIALS

fischertechnikTM Universal II kits



SCHEDULE

60 Minute Lesson

- Introduction (10 minutes)
- Block Flipper Build & Optional Challenge (40 min)
- Clean Up & Wrap-Up (10 minutes)

OBJECTIVE

Build a block flipper to explore first class levers.

PREP

Read the background info and review today's lesson. For a more in-depth tutorial on this lesson's featured machines, review the link listed on page 5.

BACKGROUND

Simple machines are the most basic mechanical devices. They can change the direction or magnitude of a force to make work easier. (Who doesn't like that?)

It's possible that the lever is the first simple machine to be discovered and used. Levers are easily assembled from materials including sticks and rocks. As a matter of fact, many primates are capable of creating and using levers in the wild to pry bugs and other food out of the ground!

Levers transfers effort to make work easier and has three parts to its design: the effort, the fulcrum and the load. As a lever pivots on the fulcrum, the effort used to push or pull on the lever is transferred to the load.

Humans use levers every day. Some common levers include those found on crowbars, wheelbarrows, nutcrackers, and scissors. There are three different classes of levers based on the relationship between the position of the fulcrum, load and applied force (effort). In first class levers, the fulcrum is between the effort and the load.

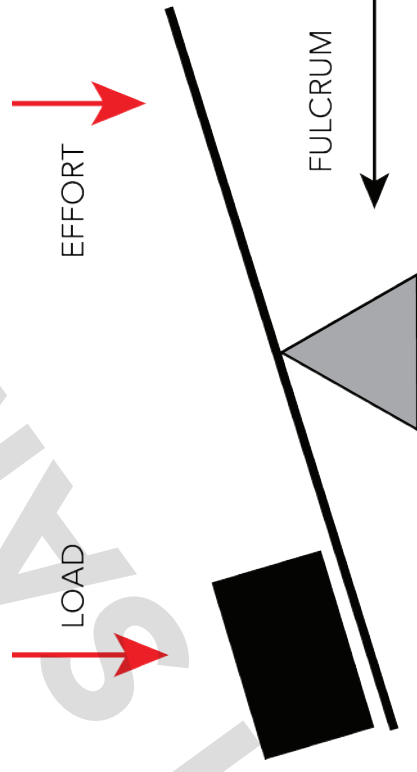

VOCABULARY

Effort: The effort is the force applied to the lever, as in, the effort it takes someone to move it.

First class lever: A lever with a fulcrum between the effort and the load.

Fulcrum: The fulcrum allows the lever to move. It's the point along the lever arm that gives it the freedom to rotate. This could be a hinge or even a rock under a board.

Lever: A simple machine that includes a rigid object that can pivot on a fulcrum and transfer effort to a load to make work easier.

Load: The load is the object that is loaded onto the lever.

Simple machine: The most basic mechanical devices able to increase an applied force, making work easier.

INTRODUCTION DISCUSSION QUESTIONS

- How many different everyday first class levers can you think of? (See-saw, crowbar, pliers, scissors, a hammer pulling a nail, flexing arm muscle, an old-fashioned balance scale...)
- What makes first class levers different from other types of levers? (The fulcrum is between the effort and the load.)

CHALLENGE—OPTIONAL

Create a Super Block Flipper that is able to launch a Building Block 15 a distance of four meters or about 6 normal-sized steps. Experiment with the length of the lever arm on each side of the fulcrum to maximize the distance.

WRAP-UP QUESTIONS

- What was most challenging about building the block flipper?
- If you had more time, what are some ideas of ways of modifying the block flipper to make it better or even transform it into a different machine?

ALIGNED STANDARDS

NGSS 3-5 ETS1-1 Define a simple design problem reflecting a need or a want that includes specified criteria for success and constraints on materials, time, or cost.

NGSS 3-5 ETS1-2 Generate and compare multiple possible solutions to a problem based on how well each is likely to meet the criteria and constraints of the problem.

21ST CENTURY SKILLS

Creativity and Innovation • Critical Thinking and Problem Solving

HABITS OF MIND

Striving for Accuracy • Creating, Imagining, Innovating

1ST CLASS LEVERS

Block Flipper

Materials

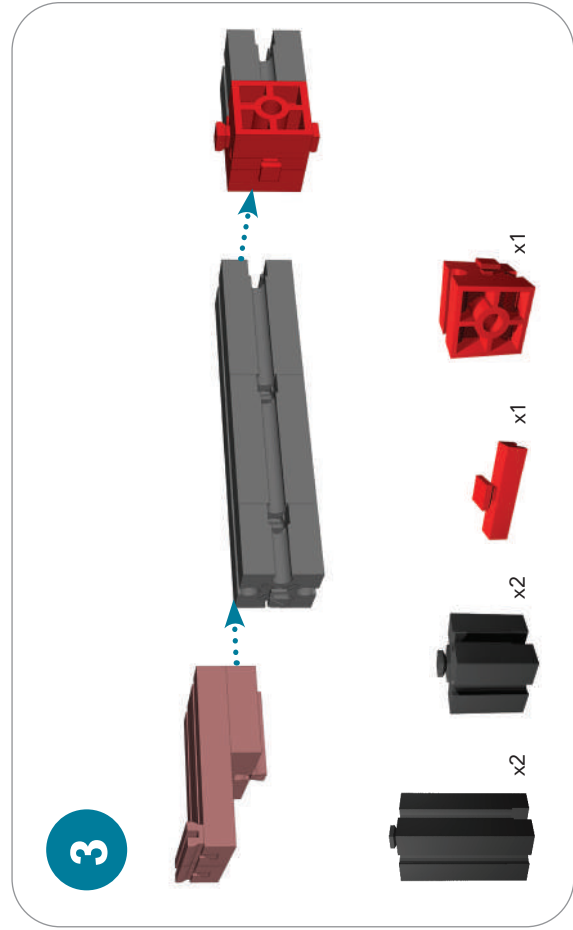
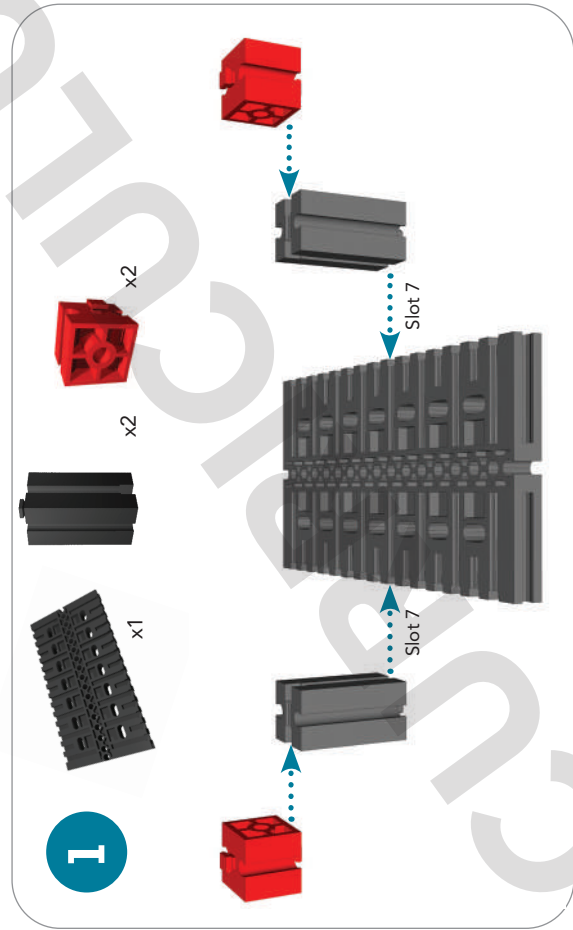
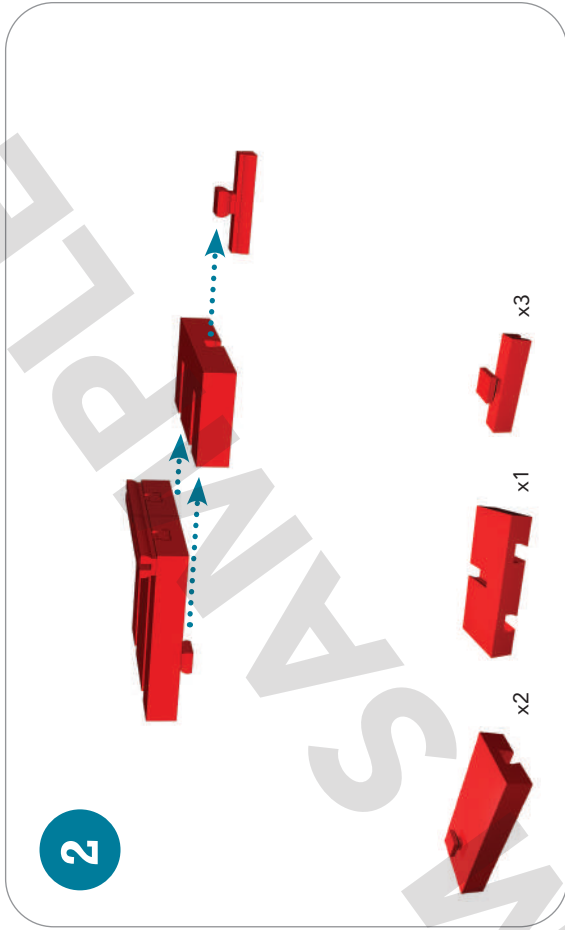

1ST CLASS LEVERS

Block Flipper

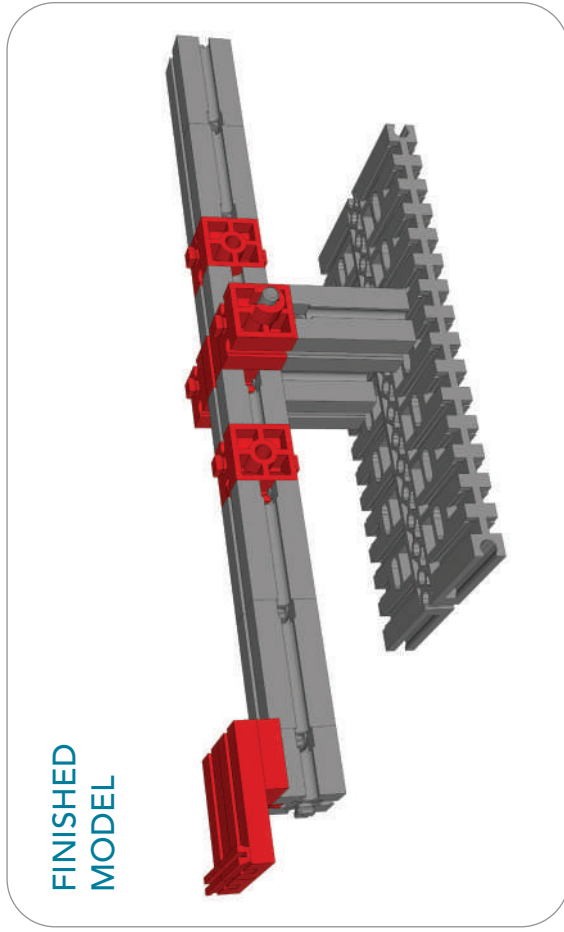
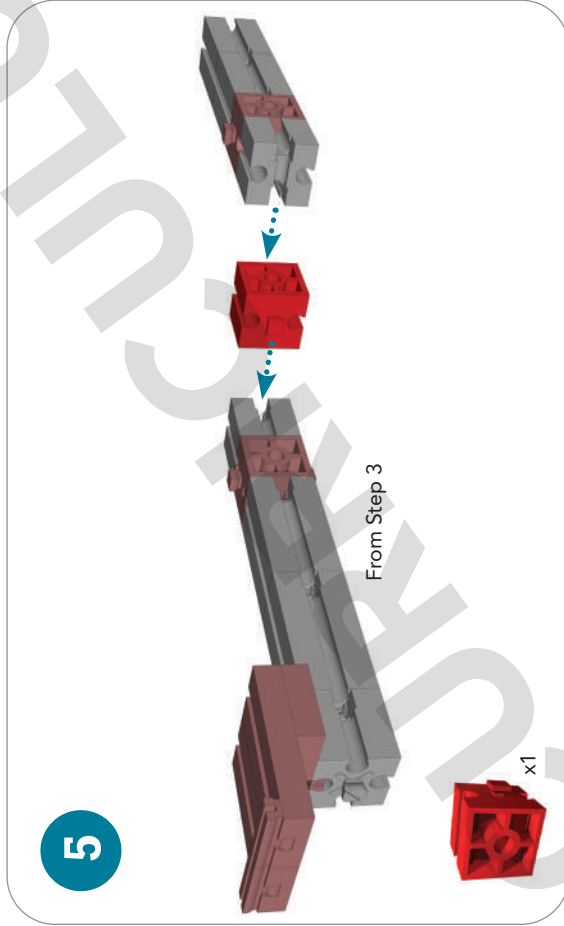
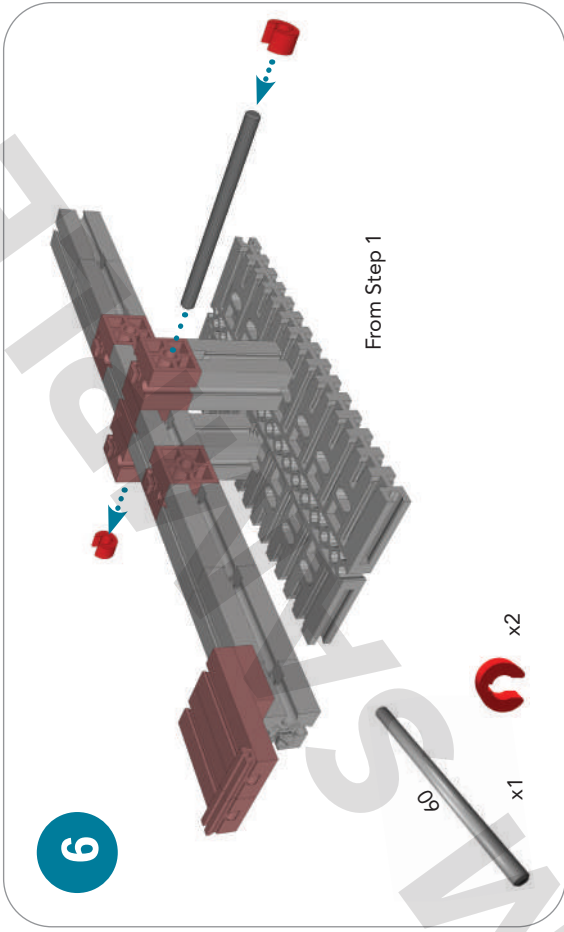
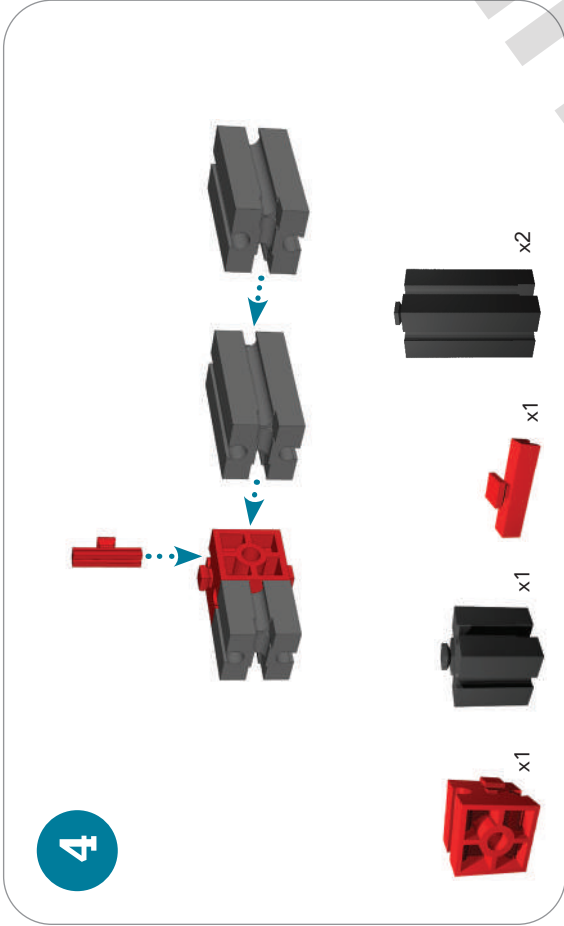



Need a Custom Solution?

Call: (208) 343-3110

Email: sales@edventures.com

Web: edventures.com



PCS edventures!TM
 Experts in Hands-On **STEM** Education

