

Discover Engineering Grades 4-8

CURRICULUM SAMPLE

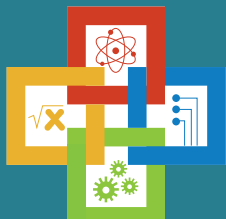

DISCOVER

edventures.com

sales@edventures.com

(208) 343-3110



Discover Engineering

GRADES: 4-8



<p>STUDENTS Up to 6 per kit</p>	<p>TIME 25+ Contact Hours</p>
<p>SUBJECTS</p> <ul style="list-style-type: none"> • Technology • Engineering Design 	<p>SETTINGS</p> <ul style="list-style-type: none"> • Before & After-school programs • Classrooms • Libraries and makerspaces • Homeschools

COMPLETE PROGRAM

This **reusable** kit prepares students to adapt to today's evolving technology. With wheels, pulleys and gears, this **scaffolded** curriculum uses the engineering design process to build complex systems.

♻️ 100% reusable

TECH REQUIREMENTS

- None

PRICING OPTIONS

- Single Kit (1 kit): \$525⁰⁰
- Club Pack (5 kits): \$2,525⁰⁰
- Classroom Pack (8 kits): \$3,995⁰⁰



PRINT MATERIALS



SAMPLE BUILD

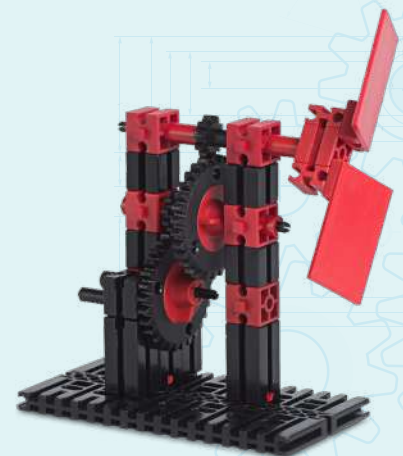

SCAN OR CLICK QR CODE FOR:

[PRODUCT ORIENTATION](#)

[FULL MATERIAL LIST](#)

[STANDARDS & ALIGNMENT](#)

CONTACT US:

Call: (208) 343-3110

Email: sales@edventures.com

Web: edventures.com



Project
#1

PULLEYS

Engineering

Pulley System

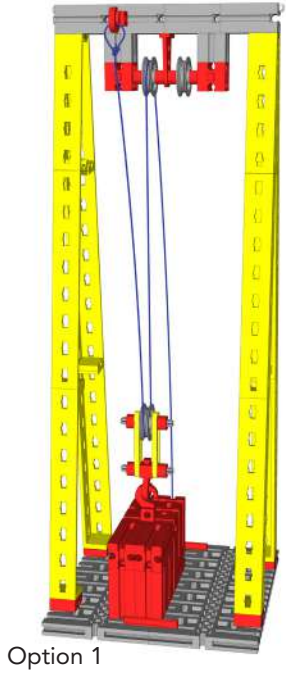

Option 1

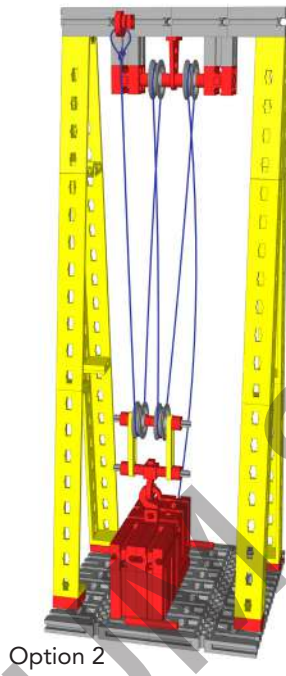

Option 2

Each step is color coded in order of assembly.











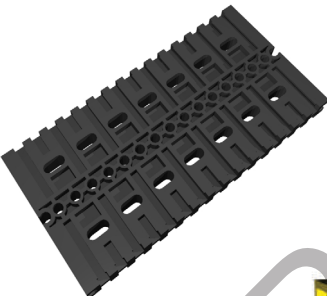





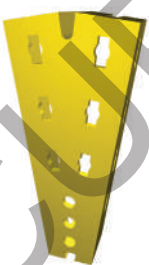



- First
- Second
- Third
- Fourth
- Fifth
- Sixth

Icon Legend

- Set assembly aside.
- Build the number shown.
- Rotate assembly.
- Flip assembly.

Materials you will need:

*some part colors may vary

					
Base Plate 120x60 (Qty 2)	Building Block 30 (Qty 19)	Building Block 15 with Bore (Qty 2)	Building Block 15 (Qty 2)	Link 30 (Qty 2)	String (Qty 1)
					
Angle Girder 7.5 (Qty 2)	Angle Girder 120 (Qty 8)	Angle Block 7.5 (Qty 4)	Coupling 30 (Qty 1)	Hook (Qty 5)	Spring Cam (Qty 6)
					
Rope Pulley 21 (Qty 5)	Metal Axle 60 (Qty 1)	Metal Axle 125 (Qty 1)	Clip Axle 30 (Qty 2)	Clip Axle 45 (Qty 2)	I-Strut 30 (Qty 4)
					
Clip 5 (Qty 12)	Spacer Ring (Qty 6)				

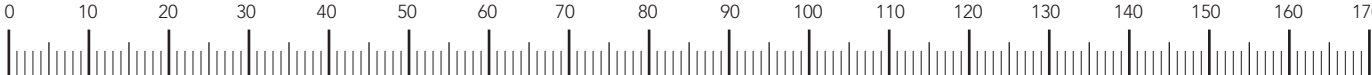

■ First ■ Second ■ Third ■ Fourth ■ Fifth ■ Sixth

1



Shown in actual color.

Parts shown in color-coded building order.

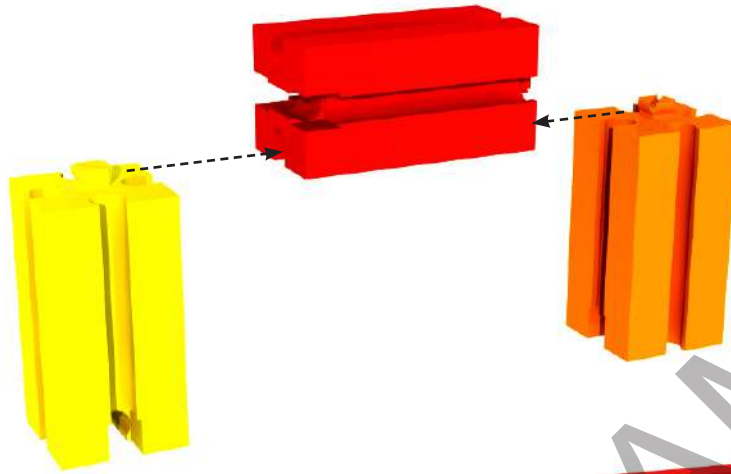

All steps have an "exploded view" which helps with assembly.

The assembly should look like this before proceeding to the next step.



x5

2

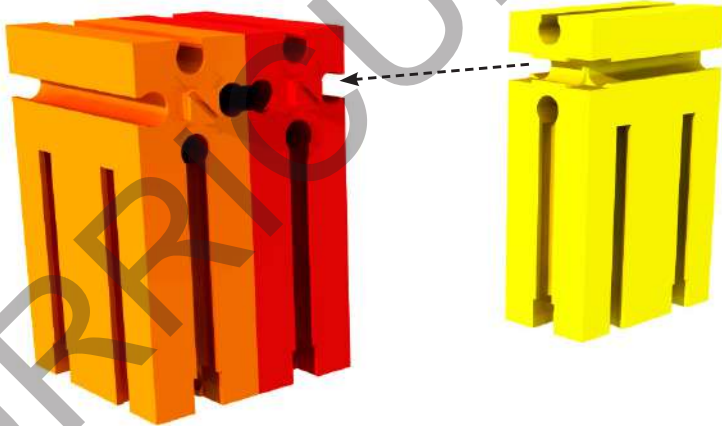

■ First
 ■ Second
 ■ Third
 ■ Fourth
 ■ Fifth
 ■ Sixth

17



x2



x1



x1



x2



x4

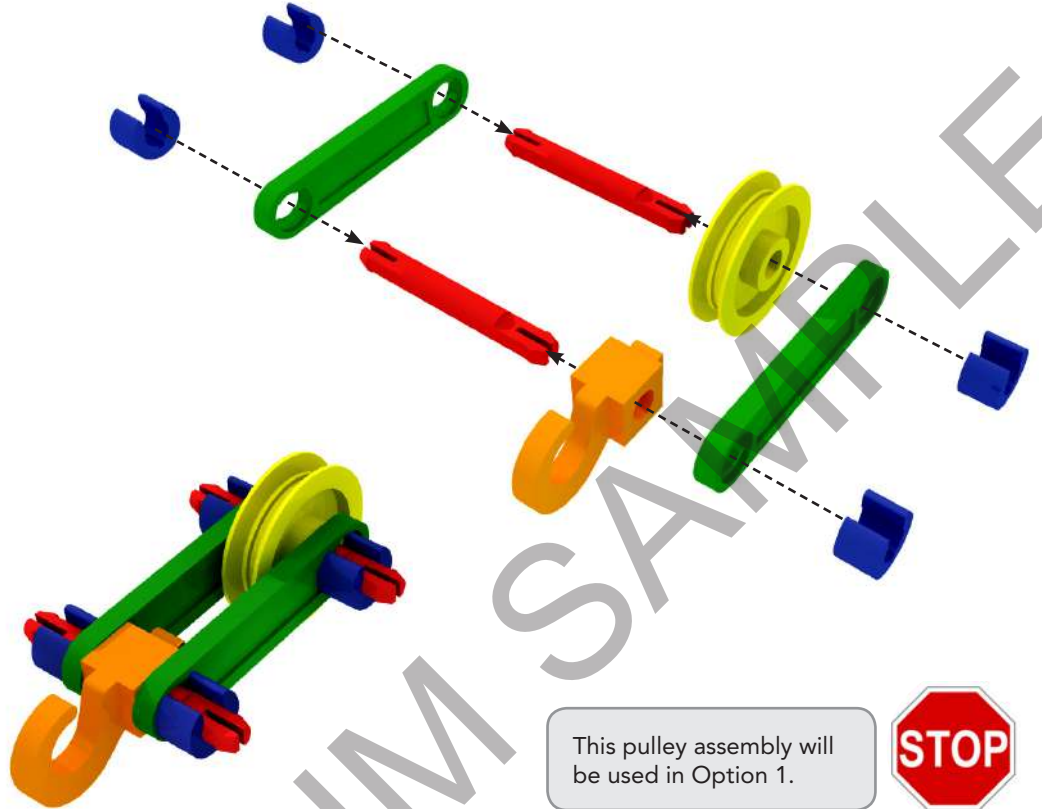

This pulley assembly will be used in Option 1.



18



x2



x1



x6



x2



x2



x4

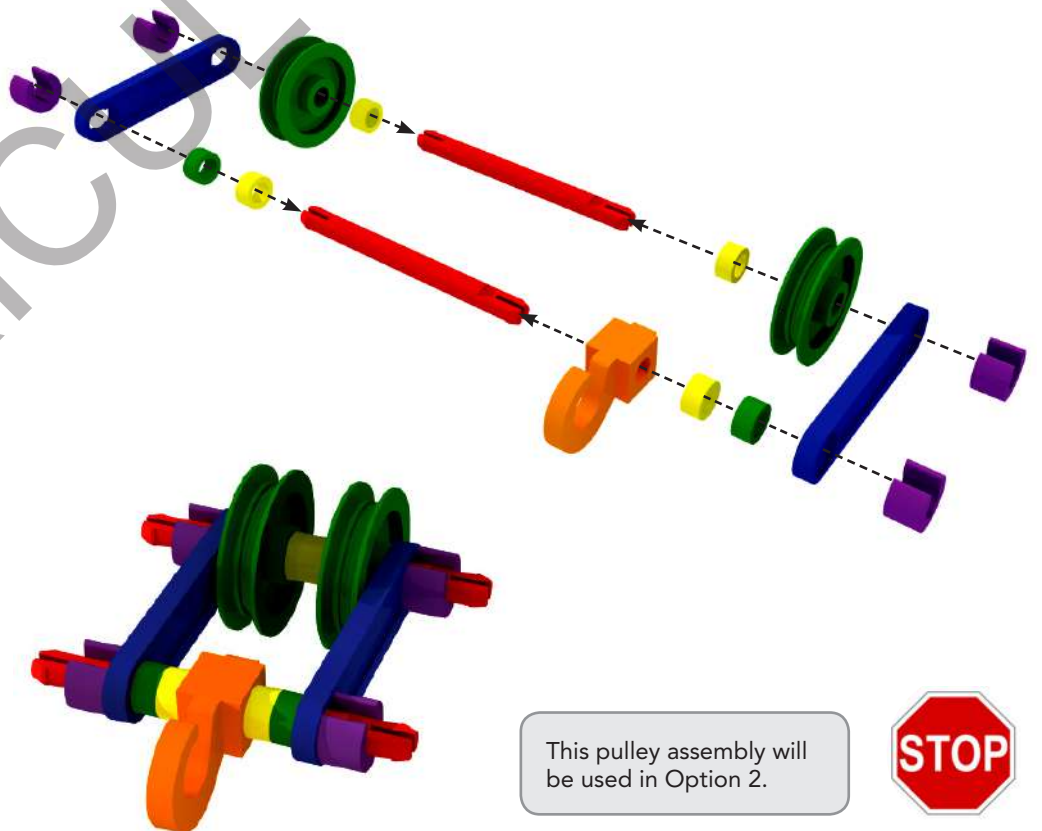

This pulley assembly will be used in Option 2.



Option 1

Start

Tie the end of the string around the top Hook.

From Step 17

From Step 4



Tie a small loop in the string to hold, or to hook on to the bottom hook.

Option 2

Start

Tie the end of the string around the top Hook.

From Step 18

From Step 4

Tie a small loop in the string to hold, or to hook on to the bottom hook.

Finished Model

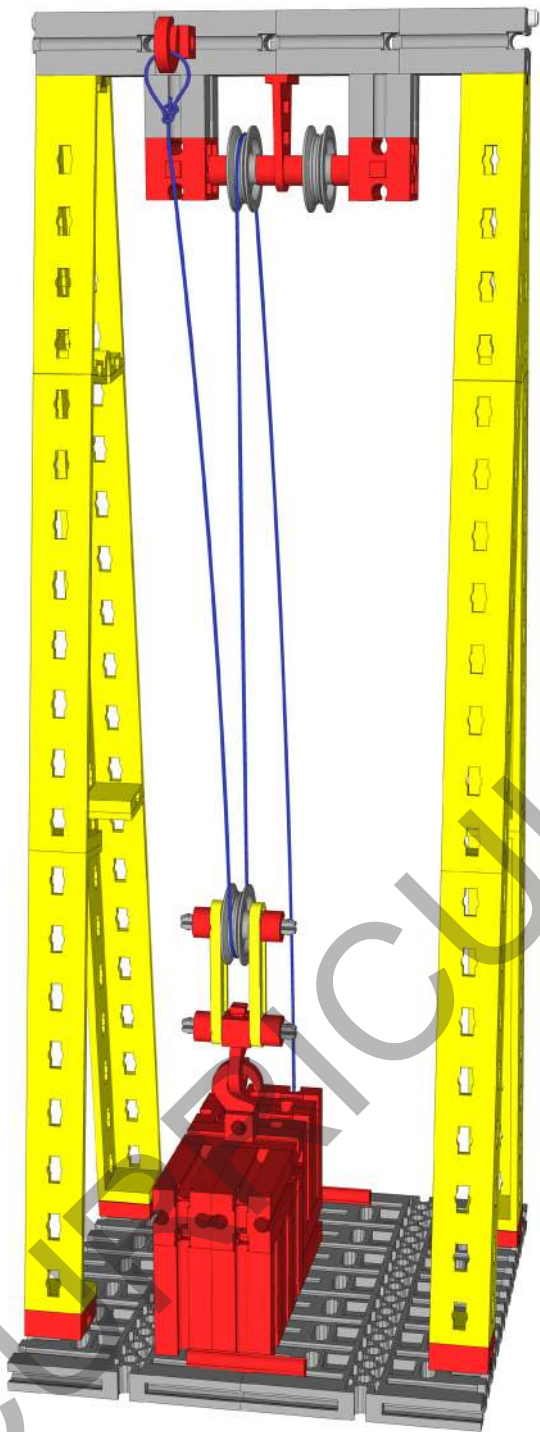

Option 1

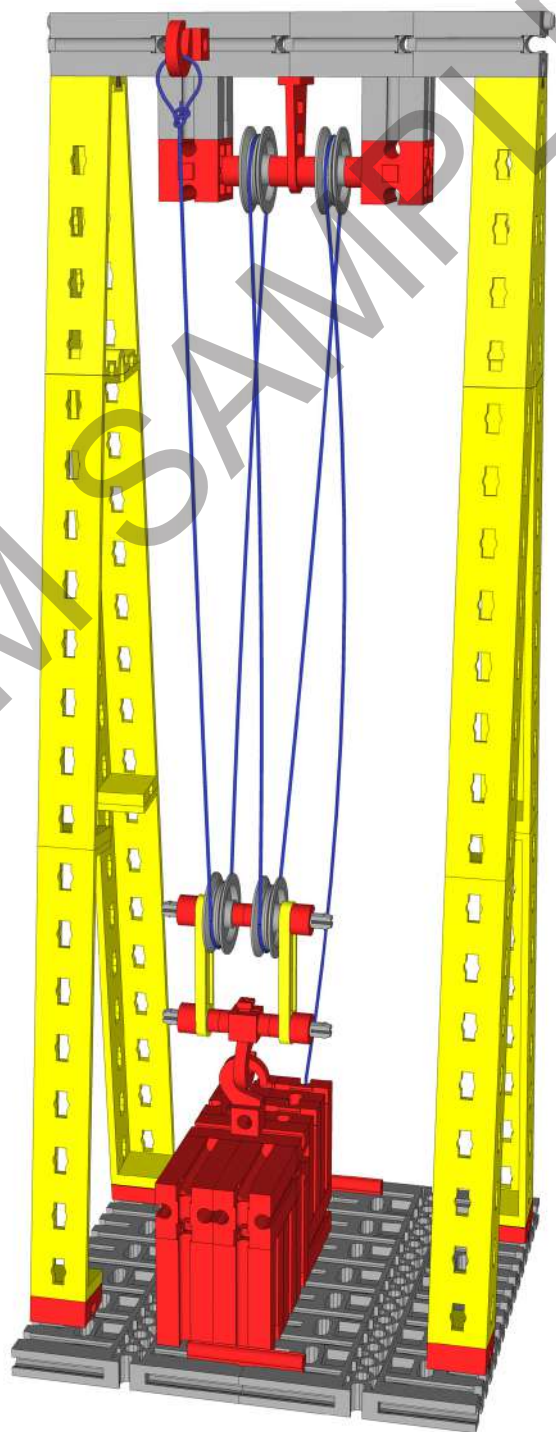

Option 2



Need a Custom Solution?

Call: (208) 343-3110

Email: sales@edventures.com

Web: edventures.com

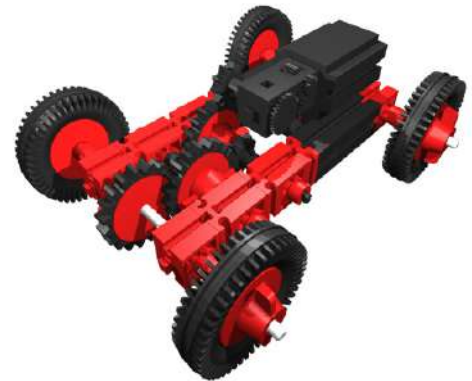

PCS edventures!™
Experts in Hands-On **STEM** Education

